

Panasonic

NEW

High Performance Compact Inverters

MK300 Series

Accurate control based on perfect function



200V 0.2 kW / 0.4 kW / 0.75 kW / 1.5 kW / 2.2kW

NEW

400V 0.75 kW / 1.5 kW / 2.2 kW / 3.7 kW

400V 5.5 kW / 7.5 kW / 11 kW / 15 kW

NEW

Compact inverters with industry-leading control performance

- Top class overload and high-torque performance among small models
- Mode-selectable sensorless vector control function
- Selected for dual-specification of standard load and light load

Drive common motor without encoder to achieve high precision and high response speed.

200% torque output can be achieved at speed as low as 0.5Hz (in sensorless vector control mode).

Note) 150% torque output at 0.5Hz for 5.5kW or more

Speed - torque characteristics example

AMK3001P54 (sensorless vector control)

Motor: 1.5kW 4P

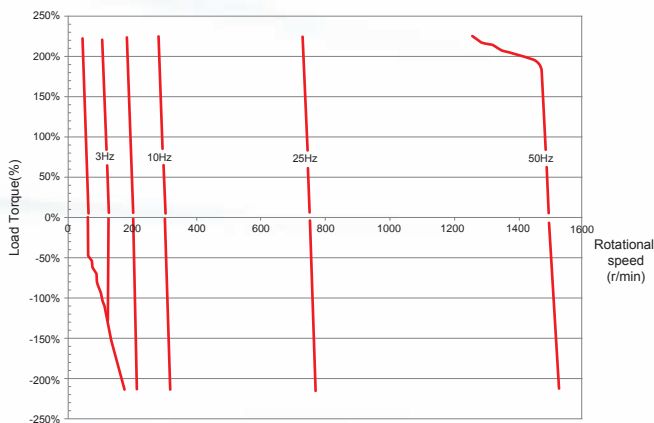

The product has clearly marked inverter power performance, which serves as a reference to the user in model selection.

The effect of "small horse drawing a big car" can be realized for particular industries.

• Standard load specification

Overload current rating: 150% of rated output current, 1 minute.
It can address motor applications of standard load specification of the current inverter.

• Light load specification

Overload current rating: 120% of rated output current, 1 minute.
It can address motor applications that are one grade higher than the current inverter specification.

Conveyor control application

With torque control, superior driving power can be exerted in applications such as low speed starting.

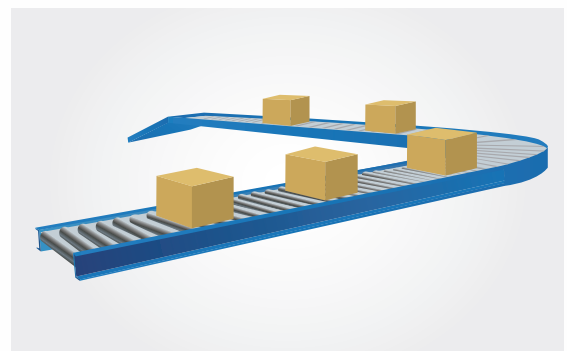

A rich variety of functions and applications

- Provided with a high-speed current limiting function

Even if excessive current flows momentarily due to load variation, MK300 will continue operation instead of tripping, thus improving productivity. It is effective for rapid acceleration of heavy-duty turntable and stirring of viscous substances like bread and flour, etc.

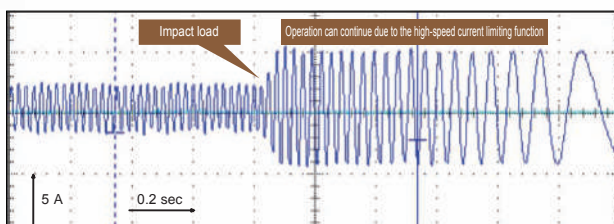

200V 0.2kW
200V 0.4kW



200V 0.75kW
200V 1.5kW
400V 0.75kW
400V 1.5kW



200V 2.2kW
400V 2.2kW
400V 3.7kW

• Corresponds to textile winder function

Textile winding reciprocal operation function will operate at the triangular-wave-shaped frequency as shown in the following graph.

Textile winding reciprocal operation function

Winding mode control function will operate at the triangular-wave-shaped frequency as shown.

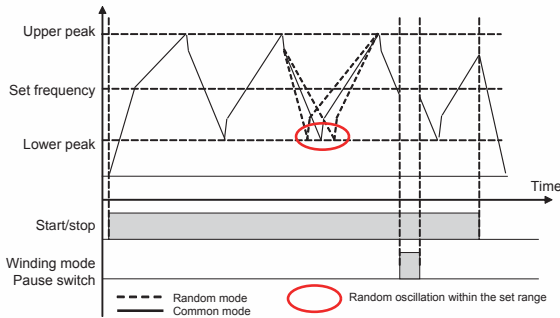

More operation modes:

- **Random oscillation mode** Effectively prevent the windings from stacking on the same point
- **Winding length stop mode** The function of auto stop when the winding accumulatively reaches a certain length
- **Pulse input length calculation mode** It facilitates the display and statistics of winding length, and the calculation results can be communicated
- **Two-point mode** The reference frequency is smoothed with the winding length, and finally changes to the second frequency

Textile machinery application

Applied in most textile equipment using inverters.

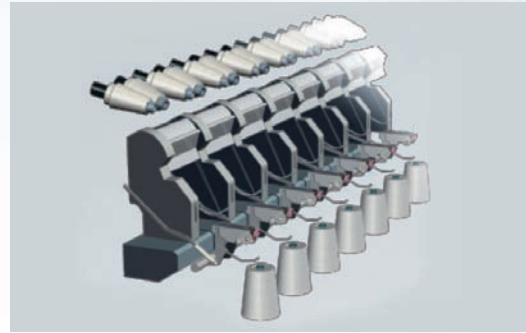

Convenient operation

• Quick selection operation with knob

It includes a knob for confirming buttons, which enables quick selection and setting when selecting parameters.

The operational speed and precision are improved.



Rotation selection parameter



Button confirmation parameter

Free maintenance

• Simple exchange of cooling fan

The exquisite design at the cooling fan makes it more convenient to replace the cooling fan. The product maintenance efficiency is greatly improved.



400V 5.5kW
400V 7.5kW

400V 11kW
400V 15kW

Accessories

Product name	Model	Product image	Supply voltage	Communication pattern	Function	Main features
MK300 operation panel	AMK300-REM1		MK300 inverter body power supply (+5V)	RS485	Remote operation function Parameter copy function Inverter multi-unit control function	<ul style="list-style-type: none"> Requires no other power supply (MK300 body power supply) Requires no special connecting cable (can be connected using commercially available standard LAN cable) Can be installed using two M3 screws

The water tank pump pressure is controlled using our small PLC<FP-XH> and MK300

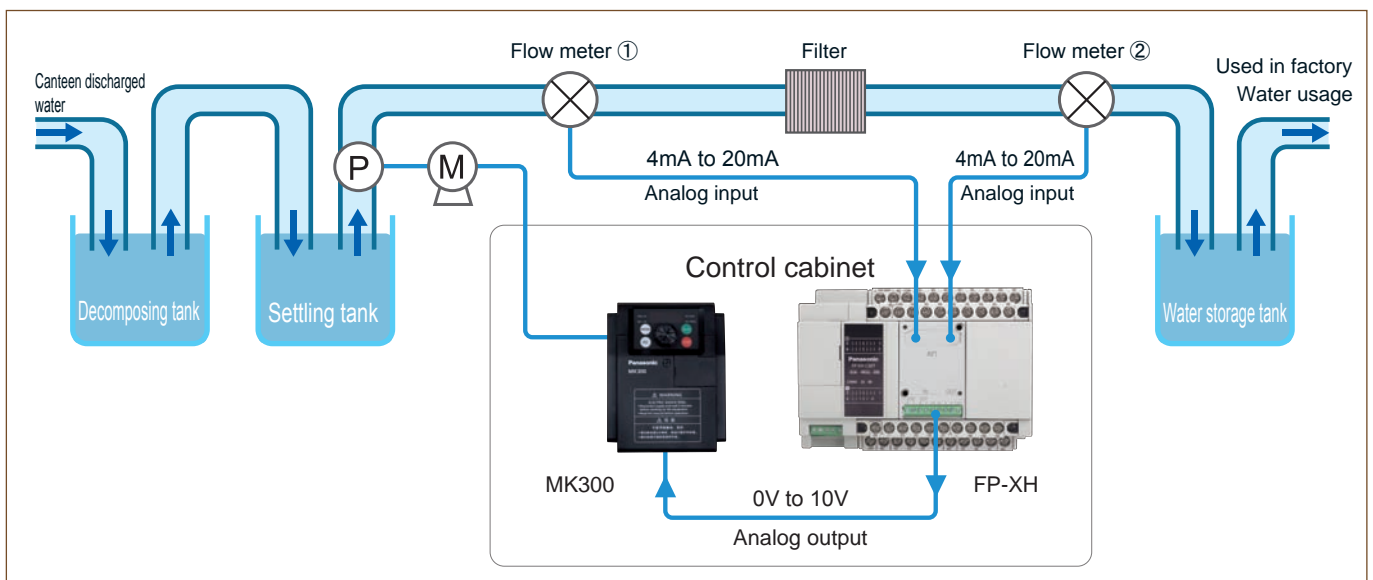

Application description

- The water discharged from the factory canteen is bacterially decomposed, and the fresh water accumulated in the settling tank is drawn using a pump, and after filtration using a filter, the water is sent to the storage tank as industrial water.
- MK300 is used to control the motor speed so as to regulate the pump pressure.
- PLC[FP-XH] is used to output speed instructions to MK300, and (0V-10V) is used to analog signal.
- The speed instruction output from FP-XH (0V-10V analog output) is based on the value of flow meter ②. After the value of flow meter becomes small, the analog output value is increased in order to boost the pump pressure.
- After the value difference between flow meter ① and flow meter ② exceeds a certain value, it is judged that the filter is clogged, and a replacement signal is output from FP-XH.
- After installing the analog I/O plug-in (AFPX-A21) onto FP-XH, the analog input of two flow meters and analog output of MK300 can be realized, and by utilizing the expanded plug-in of small installation area in combination with inverter MK300, great contribution can be made to the miniaturization of control cabinets.

Small programmable controllers FP-XH series product introduction

- High speed, high performance**
Basic instructions: 0.04ms within 5k steps; Large capacity of 32k by default (16k for 14-point model), programs/registers 3-phase capacity changeover.
- Position control**
All channels, maximum speed up to 100kHz, maximum 6-channel high-speed pulse output, versatile motion control including linear interpolation, home return, repetitive motion, etc.
- Scalability and compatibility**
A full lineup of expansion cards and expansion units, up to 452 points; simultaneous extended 4ch communication; used in common with the existing FP-X program.
- Communication**
Terminal block type RS232C communication port, cardless PC-Link; expanded RS485 communication card, enabling data share among up to 16 control units.



RATINGS

Item		1-phase 200 V Input Type (Model AMK300□□□2)					3-phase 400 V Input Type (Model AMK300□□□4)							
		0P2	0P4	0P7	1P5	2P2	0P7	1P5	2P2	3P7	5P5	7P5	011	015
Standard load specification	Applicable motor output (kW) *1	0.2	0.4	0.75	1.5	2.2	0.75	1.5	2.2	3.7	5.5	7.5	11.0	15.0
	Rated output current (A) *2	1.5	3.0	5.0	8.0	11.0	2.6	4.0	6.0	9.5	12.0	17.0	23.0	31.0
	Rated output capacity (kVA) *3	0.6	1.2	2.0	3.2	4.4	2.1	3.2	4.8	7.6	9.6	13.5	18.3	24.7
	Rated input current (A) *4	3.9	8.0	12.6	18.5	23.8	3.9	6.0	9.0	14.3	15.6	22.1	29.9	40.3
	Power supply capacity (kVA) *4	0.9	1.8	2.9	4.3	5.5	3.1	4.8	7.2	11.4	12.4	17.6	23.8	32.1
Light load specification	Applicable motor output (kW) *1	0.4	0.75	1.5	2.2	3.0	1.5	2.2	3.7	5.5	7.5	11.0	15.0	18.5
	Rated output current (A) *2	1.9	3.5	6.0	9.6	12.0	3.6	5.4	6.9	11.1	17.0	17.0	31.0	38.0
	Rated output capacity (kVA) *3	0.8	1.4	2.4	3.8	4.8	2.9	4.3	5.5	8.8	13.5	13.5	24.7	30.3
	Rated input current (A) *4	5.1	9.1	15.2	22.3	25.8	5.4	8.1	10.4	16.7	22.1	22.1	40.3	49.4
	Power supply capacity (kVA) *4	1.2	2.1	3.5	5.1	5.9	4.3	6.5	8.2	13.3	17.6	17.6	32.1	39.4
Weight (kg)		Approx. 1.0	Approx. 1.0	Approx. 1.4	Approx. 1.6	Approx. 2.0	Approx. 1.5	Approx. 1.6	Approx. 1.9	Approx. 2.0	Approx. 3.6	Approx. 3.6	Approx. 8.2	Approx. 8.3

*1 "Applicable motor output" refers to the maximum applicable capacity of standard 4-pole motor. Make sure that the rated output current of inverter is higher than the rated current of motor during inverter selection.

*2 The rated output current of inverter varies with the set carrier frequency. Derate the output current for use.

*3 Rated output capacity refers to the value at output voltage of 230 VAC for 1-phase 200V input type and the value at output voltage of 460 VAC for 3-phase 400V input type.

*4 The power supply capacity varies with the impedance at its side. Prepare the power supply with capacity larger than values shown in the above table.

Terminals for main circuit

1-phase 200V / 0.2kW, 0.4kW

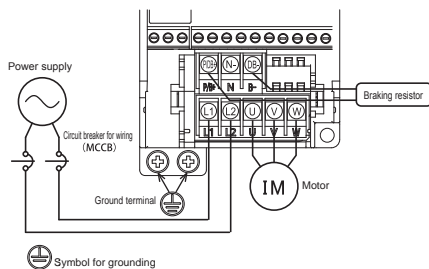

1-phase 200V / 0.75kW-2.2kW

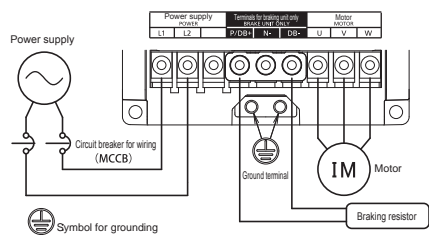

3-phase 400V / 0.75kW-15kW

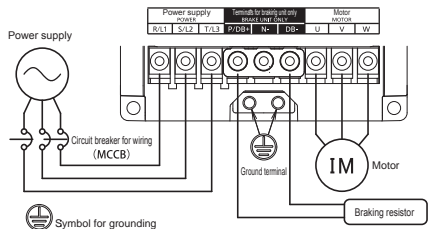

Functions of terminals for main circuit

Terminal No.	Terminal name	Descriptions of terminal function
R/L1, S/L2, T/L3 L1, L2	Power supply for main circuit	Power supply for main circuit For 1-phase 200 V type, connect to terminal L1 and L2
U, V, W	Inverter output	Connects to 3-phase motor
P/DB+, DB-	Braking resistor connection	Connects to braking resistor
N-	Internal DC voltage (negative)	Negative terminal of internal DC voltage
⊕ x2	Grounding	Ground terminal 1-phase 200V: ground resistance 100 Ω or less 3-phase 400V: ground resistance 10 Ω or less Ground the neutral of power supply

Terminals for control circuit

Control circuit terminal arrangement

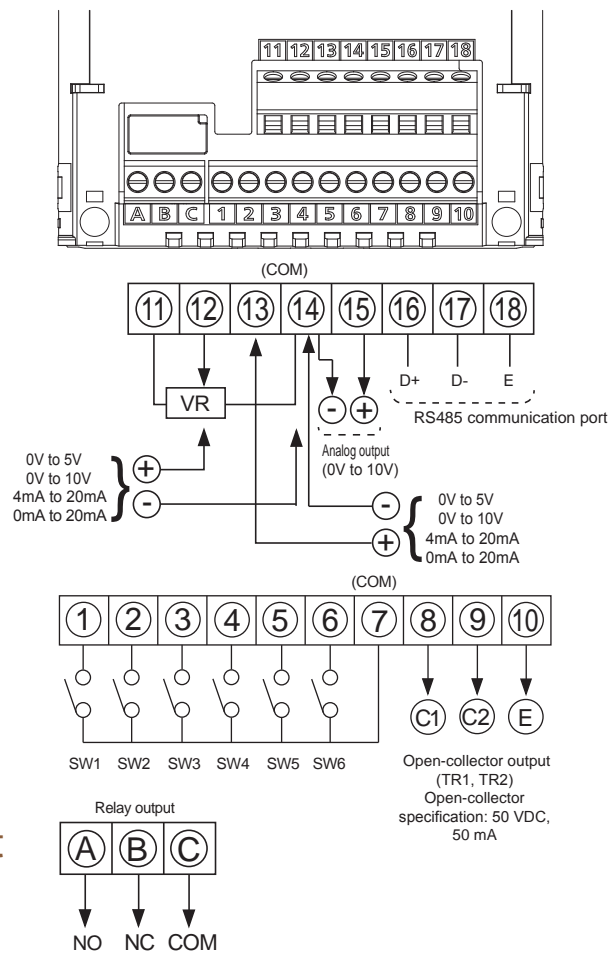

VR specification: 10 kW, 1/4 W or higher potentiometer

Relay specification: 1c non-voltage contact
230 VAC 0.25 A (resistive load)
30VDC 1 A (resistive load)

Specification

Item		Specification	
Standard output of applicable motor (kW)		0.2 kW to 2.2 kW	0.75 kW to 15 kW
Rated output	Rated voltage	1-phase 200V-230VAC (proportional to power supply voltage)	3-phase 380V-460VAC (proportional to power supply voltage)
	Overload current rating	Standard load specification: 150% of rated output current, 1 minute Light load specification: 120% of rated output current, 1 minute	
Input power supply	Phase number/Voltage/Frequency	1-phase 200V-230VAC 50Hz/60Hz	3-phase 380V-460VAC 50Hz/60Hz
	Allowable voltage fluctuation	+10% and -15% of rated input AC voltage	
	Allowable frequency fluctuation	±5% of rated input frequency	
	Instantaneous voltage drop ride-through capability	<ul style="list-style-type: none"> • Operation continues when voltage is above 165 VAC. • Operation continues for 15 ms when voltage drops below 165 VAC. 	<ul style="list-style-type: none"> • Operation continues when voltage is above 323 VAC. • Operation continues for 15 ms when voltage drops below 323 VAC.
Output frequency	Frequency range	V/F control: 0.2 Hz to 400 Hz Sensorless vector control: 0.5 Hz to 120 Hz	
	Frequency display	Digital display	
	Frequency precision	Analog setting: within ±0.5% of maximum set frequency (25°C±10°C) Digital setting: within ±0.01% of maximum set frequency (-10°C to +50°C)	
	Frequency resolution	Analog setting: 0.1 Hz (in 50/60 Hz mode) Digital setting: 0.1 Hz	
Inverter control mode		High carrier frequency sinusoidal PWM control (V/F control or sensorless vector control is available.)	
Carrier frequency(Note 3)		<ul style="list-style-type: none"> • V/F control setting: 9 options (adjustable from 0.8 to 15 kHz) can be selected. • Sensorless vector control setting: 6 options (adjustable from 2.5 to 15 kHz) can be selected. (0.8kHz, 1.1kHz, 1.6kHz, 2.5kHz, 5.0kHz, 7.5kHz, 10.0kHz, 12.5kHz, 15.0kHz) 	
Run	Start/Stop	<ul style="list-style-type: none"> • Operation panel switches • 1a contact signal and 3-wire input (1a and 1b contact signals) can be selected. • RS485 communication • Wait time (0.1 to 100 s) can be set. 	
	Forward/Reverse run	<ul style="list-style-type: none"> • Operation panel switches • 1a contact signal (reverse run can be disabled.) • RS485 communication 	
	Jogging operation	Operating frequency: adjustable from 0.2 to 400 Hz Acceleration / deceleration time: adjustable from 0.04 to 3600 s	
	Stop Mode	Deceleration stop / coast-to-stop (switchable)	
	Reset function	Reset by stop signal/reset by external device/reset by operation panel(optional) / reset by power supply	
	Starting Frequency	Adjustable from 0.2 to 60 Hz	
	Stop Frequency	Adjustable from 0.2 to 60 Hz	
	Ride-through restart selection	0 Hz restart/operation frequency restart/speed search restart (switchable)	
	Speed search	Speed search during startup (optional)	
Retry function	Retry selection: validity of function, selection of details of retry faults Retry operations: adjustable from 1 to 10 operations		
Control	Frequency setting signal	Panel setting (operation panel): digital setting Analog setting signal input from external control: <ul style="list-style-type: none"> • Potentiometer (10 kΩ, 1/4 W or higher) • 0V to 5V DC, 0V to 10V DC • 4 mA to 20 mA, 0 mA to 20 mA Digital setting signal input from external control: <ul style="list-style-type: none"> • PWM signal (signal cycle: 1 to 2000 ms), pulse input signal • Frequency rise SW/reduction SW/storage SW signal Communication setting: RS485	
	Frequency/Voltage characteristics	Base frequency: fixed at 50/60 Hz, adjustable from 45 to 400 Hz 3-point V/F mode: adjustable voltage and frequency V/F curve: constant/reduced torque mode (switchable)	
	Torque boost	Adjustable from 0 to 40%/auto torque boost (switchable)	
	Acceleration/deceleration time	0.04 to 3600 s (independent acceleration/ deceleration setting)	
	Acceleration/deceleration characteristics	Linear and S-shaped acceleration/deceleration (switchable)	
	2nd function selection	2nd function selection (acceleration/deceleration time, torque boost, V/F characteristics (base frequency/3-point V/F mode), electronic thermal and analog frequency setting)	
	Multi-step speed frequency setting	<ul style="list-style-type: none"> • Multi-step speed operation: up to 16-step speed setting (No limitation to frequency setting) • Timer operation: up to 8-step speed settings (No limitation to frequency setting) It can be linked with acceleration/ deceleration time.	
	Skip frequency setting	Up to 3 settings (skip frequency band adjustable from 1 to 10 Hz)	
Upper frequency limit setting	Adjustable from 0.2 to 400 Hz		

Item		Specification
Control	Lower frequency limit setting	Adjustable from 0.2 to 400 Hz
	Bias/gain frequency setting	Bias frequency: adjustable from -99 to 250% Gain frequency: adjustable from 0 to 500%
	External stop function	External fault stop/coast-to-stop (switchable)
	PID function	PID control mode (optional)
	Offline automatic tuning function	Automatic tuning of motor constant
	Cooling fan ON/OFF control	Optional
	Communication Function	<ul style="list-style-type: none"> Port: RS485 serial communication Communication speed: 4800bps/9600bps/19200bps/38400bps/57600bps/115200bps (switchable) Protocols: MEWTOCOL-COM/Modbus-RTU/Modbus-ASCII (switchable) Communication method: half-duplex Maximum number of connected units: 31 Maximum transmission distance: 500 m (in total)
Braking	Regenerative braking torque	<ul style="list-style-type: none"> 200V 0.2 kW: 100% or higher 0.4 kW: 80% or higher 0.75 kW to 2.2 kW: 20% or higher 400V 0.75 kW to 15 kW: 20% or higher
	DC injection braking	<ul style="list-style-type: none"> Operate at the frequency below stop frequency Braking torque level: 0 to 100% Braking time: adjustable from 0.1 to 120 s
Output signal	Analog output	Output specification: 0 to 10 VDC (max. 1 mA) Output function: output frequency and output current proportion (switchable)
	Open-collector output	Output specification: max. rating 50 VDC/50 mA Output functions: operation signal, arrival signal, overload alarm, frequency detection, reverse run signal, abnormal alarm, current detection, timer OFF signal and output frequency/current proportion PWM signal (cycle: 1ms) (switchable)
	Relay output	Output specification: 1c contact (contact capacity 230 VAC, 0.25 A resistive load, 30 VDC, 1 A resistive load) Output functions: operation signal, arrival signal, overload alarm, frequency detection, reverse run signal, abnormal alarm, current detection and timer OFF signal (switchable)
Display	Operation/Control status	Output frequency, linear speed display (switchable), rotation direction Output voltage, internal DC voltage, setting frequency, communication station No., operation times of timer, alarm type, control circuit terminal status (I/O signal), operation status, PID (setting value, measured value and output value), progress of automatic tuning, accumulative operation time and accumulative operation time of fan
	Details of abnormality	Specific symbol is indicated when the protection function is activated (the latest four abnormalities are stored.)
Protection	Current limit	Current limit can be set within 1 to 200% of rated output current.
	Trip (stop)	Instantaneous overcurrent (SC1-6), abnormal temperature (OH) (Note 2) Overcurrent (OC1-3), overload and electronic thermal relay (OL), undervoltage (LU), overvoltage (OU1-3), cooling fan fault (FAn, FAn2), external fault (AU), operation fault (OP) and CPU fault (CPU)
	Stall prevention function	Overcurrent and overvoltage stall prevention
Environment	Ambient temperature and humidity	-10 to +50°C (Note 1) (without freezing) and below 90%RH (without condensation)
	Storage temperature and humidity	-25 to +65°C and below 95%RH
	Vibration	5.9 m/s ² (0.6G) or lower
	Altitude	1000 m max.
	Location	Indoor areas free of corrosive gases, flammable gases, oil mist or dust
IP protection		IP20 cabinet-mounted
Cooling method		0.75 kW or lower: natural cooling, 1.5 to 15 kW: air cooling

Note 1) It is -10 to +40°C when multiple inverters are installed side-by-side. Temperature for 5.5 to 15 kW light load specification: -10 to +40°C.

Note 2) The temperature protection level will be automatically changed when the output frequency is low.

Note 3) The carrier frequency will be automatically changed inside the inverter when the output frequency is low.

Product purchase numbering system

1-phase 200V 0.2kW-2.2kW

3-phase 400V 0.75kW-15kW

A MK300 OP7 4

①

②

③

① Series name MK300

② Applicable motor capacity
(Standard load specification)

OP2: 0.2kW	3P7: 3.7kW
OP4: 0.4kW	5P5: 5.5kW
OP7: 0.75kW	7P5: 7.5kW
1P5: 1.5kW	011: 11.0kW
2P2: 2.2kW	015: 15.0kW

③ Voltage class 2: 1-phase 200V
Voltage class 4: 3-phase 400V

DIMENSIONS (Unit: mm)

• MK300 Inverter

〈For 0.75kW or more〉

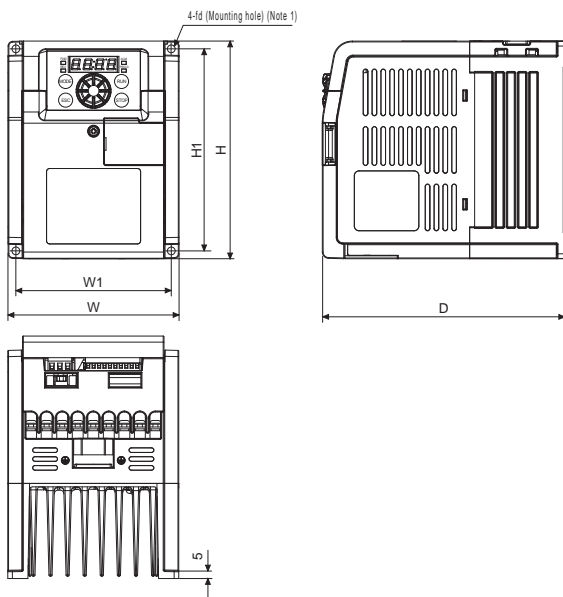

〈For 200V/0.2kW, 0.4kW〉

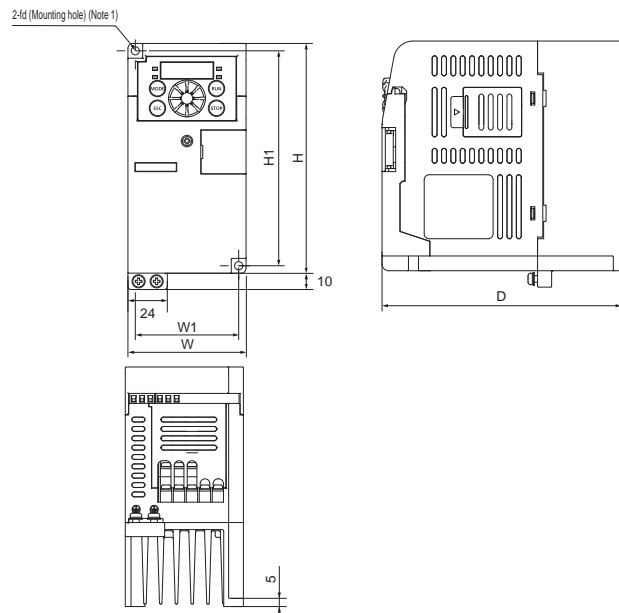

• AMK300-REM1 Operation Panel (Accessories sold separately)

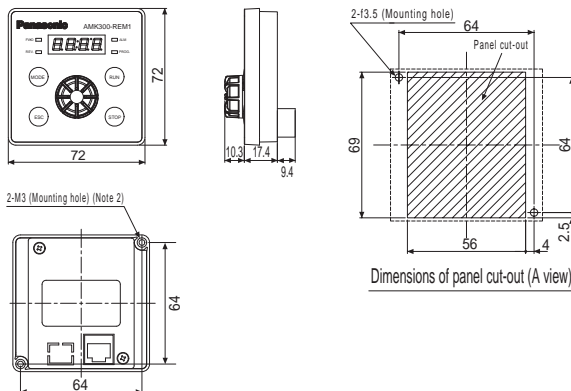

■ 1-phase 200 V Input Type

Unit: mm

Inverter capacity	W1	W	H1	H	D	Φd
AMK3000P22	63	72	131	140	146	5
AMK3000P42						
AMK3000P72	100	110	130	140	156	5
AMK3001P52						
AMK3002P22						

■ 3-phase 400 V Input Type

Unit: mm

Inverter capacity	W1	W	H1	H	D	Φd
AMK3000P74	100	110	130	140	156	5
AMK3001P54						
AMK3002P24	130	140	130	140	156	5
AMK3003P74						
AMK3005P54	150	160	190	200	185	5
AMK3007P54						
AMK3000114	204	220	265	280	185	7
AMK3000154						

【Manufacturer】 Panasonic Industrial Devices SUNX Suzhou Co., Ltd.
No.97 Huoju Road, New District Suzhou, Jiangsu Province, China

Note 1) M6 screw is used in mounting holes for AMK300114 and AMK300154, while M4 screw is used in other mounting holes.
Note 2) M3 screw is used in mounting holes.

• Please contact

Panasonic Industrial Devices Sales (China) Co., Ltd. Automation Business Office
Business consultation:

Beijing: 3F, Block C, Yuanyang Guanghua International Center, No.5 Jinghua South Street, Chaoyang District, Beijing
Shanghai: Floor 6, China Insurance Building, NO.166 East LuJiaZui Road, Pudong New District, Shanghai
Guangzhou: Floor 9, China Hotel Commercial Mansion, Liuhua Road, Yuexiu District, Guangzhou
Dalian: 6F, Modern Service Headquarters Building, No.620 Huanghe Road, Shahekou District, Dalian
Shenyang: Floor 18, Fulihua International Business Center, Block B, No.69-1 Zhonghua Road, Heping District, Shenyang
Chengdu: Room 01-03, Floor 23, Block 2, Zhonghuan Plaza, No.8 Shuncheng Avenue, Chengdu
Chongqing: Room 1701-12A, Metropolitan Plaza, No.68 Zourong Road, Yuzhong District, Chongqing
Shenzhen: Floor 8, Block 3, Jiali Construction Plaza, No.1-1 Central Fourth Road, Futian District, Shenzhen
Tianjin: Room 1001, Tianjin International Building, No.75 Nanjing Road, Heping District, Tianjin
Jiangsu: 13F, Jiangsu Yihua Hotel Office Building, No.45 North Zhongshan Road, Gulou District, Nanjing
Hangzhou: Block C, Floor 4, Zhejiang Materials & Products International Plaza, No.445, Kaixuan Road, Hangzhou
Wuhan: Room 1706-07, World Trade Building, No.686 Jiefang Avenue, Wuhan
Zhengzhou: Room 1512, Future Building, No.69 Weilai Road, Jinshui District, Zhengzhou
Xi'an: Unit 04-05, Floor 7, Zhonghai Building, No.3 South Furong Road, Qujiang New Area, Xi'an
Qingdao: Room 90A, Zhongtianheng Building, No.8 South Fuzhou Road, Shinan District, Qingdao
Xiamen: Room 2311, Bank Center, No.189 Xiahe Road, Xiamen

Tel: 010-59255988
Tel: 021-38552000
Tel: 020-87130888
Tel: 0411-88008679
Tel: 024-31884848
Tel: 028-62828333
Tel: 023-63803502
Tel: 0755-82558888
Tel: 022-58969100
Tel: 025-85288072
Tel: 0571-85171900
Tel: 027-85711665
Tel: 0371-65615120
Tel: 029-87607970
Tel: 0532-80900626
Tel: 0592-2117208

Panasonic Industrial Devices Sales (China) Co., Ltd.

Registered Address: 2F, Buildings 7 & 8, No. 88, Maji Road,
China (Shanghai) Pilot Free Trade Zone

Contact Address: Floor 6, China Insurance Building, NO.166 East
LuJiaZui Road, Pudong New District, Shanghai

Panasonic[®]

Customer Service Hotline: 400-920-9200 Fax: 400-820-7185 URL: device.panasonic.cn/ac

All Rights Reserved © 2015 COPYRIGHT Panasonic Industrial Device SUNX Suzhou Co., Ltd.

CC-MK300-1-10 201506-10YCI

Specifications are subject to change without notice.

Printed by: Akagane Computer Data Processing (Shanghai) Co., Ltd
Address: 12F, Yingshi Building, NO.180 Tianjin Road, Shanghai

Advertising